

COMPUTER CONVERSIONS CORPORATION

WWW.COMPUTERCONVERSIONS.COM
PHONE: (631)261-3300 FAX: 261-3308
6 DUNTON CT., E. NORTHPORT, NEW YORK, USA 11731

SPA & DSPH SERIES REFERENCE POWERED, HIGH VA. SYNCHRO AMPLIFIERS or D-S

FEATURES

25, 30, 100, and up to 300 VA Models
60 or 400, &, Both 60 & 400 Hz. Models
25 VA Units Deliver 100 VA+ Peak Drive
Trouble Free Isolated Inputs & Outputs
Ultra-High Efficiency, Low Distortion,
*Self-Powered off the AC Reference Input
*Internal Cool AC-Pulsating Supplies
*Very Low Loss & Heat Dissipation
Simple Bulk-Head / BackplaneMount
Very High Resistance to Shock & Vibration
High Reliability Throughout Implementation
Built-in Kick to Free Stalled Rotors
Thermal and Overload Sense & BIT Report
Output Enable & Circuit-Safe Disable Control
Transient & Short Circuit Protected Outputs
NO EXTERNAL SUPPLIES REQUIRED !

CONDUCTION COOLED BULKHEAD/BACKPLANE MOUNT



**100% REFERENCE POWERED
DRIVES ALL SYNCHRO LOADS !**

DESCRIPTION

The SPA Series "Pulsating" Synchro Power Amplifiers, and DSPH Series High Power Digital to Synchro Converters, are proven, high efficiency, low cost, compact, reliable solid state synchro drivers; designed for demanding Naval/Maritime, Aircraft, fire control and Radar/Antenna related, applications. They are commonly used on synchro based data transmission, retransmission, simulation, and instantaneous absolute position indicating and active control systems.

The SPA series accept any 3 wire synchro, or 4 wire sine/cosine resolver inputs. The DSPH Series accept upto 16 bits of parallel binary data inputs, either providing an efficient high power 3 wire synchro output, capable of driving direct and multiple large synchro loads. Models range from 25VA and

30VA continuous/ 100VA peak, 50VA/200VA peak, and 100VA/400VA peak, selections standard product, and upto 300VA / 1000+VA peak units can be provided on special app's.

All Models are completely powered from the AC reference input, eliminating the need for any large and very expensive (heat generating) linear DC supplies.

Installation is easy: in most synchro booster- amplifier, repeater, and retransmission applications; simply treat it like a synchro; mount it, wire your 5 synchro source leads, 3 synchro destination leads, and your running!

For high power D-S applications; the digital to synchro converter is built into and completely powered by the amp. To install D-S units, simply apply your 14 or 16 bit digital TTL

TYPICAL APPLICATION EXAMPLE

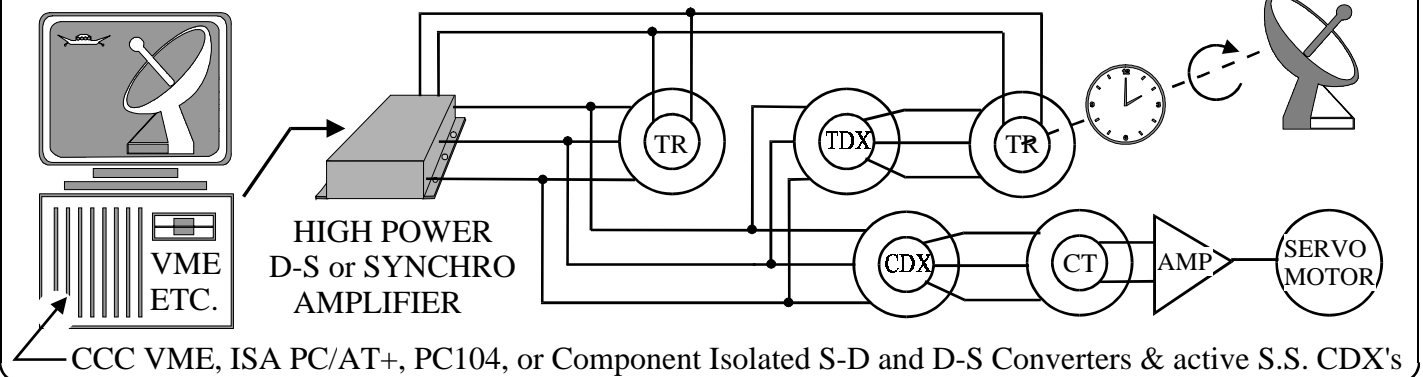

CCC VME, ISA PC/AT+, PC104, or Component Isolated S-D and D-S Converters & active S.S. CDX's

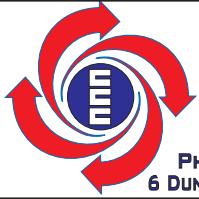

**COMPUTER
CONVERSIONS
CORPORATION**

WWW.COMPUTERCONVERSIONS.COM
PHONE: (631)261-3300 FAX: 261-3308
6 DUNTON CT., E. NORTHPORT, NEW YORK, USA 11731

SPA & DSPH SERIES
REFERENCE POWERED, HIGH VA.
SYNCHRO AMPLIFIERS or D-S pg.2

data in lieu of a synchro input and your running. The input is continuous and the input to output throughput is less than 100Usec. D-S options include: Data Latch inputs for synchronous or strobed data transfer and high-byte/low-byte latched enable inputs for use with either an 8 or 16 bit data bus.

DYNAMIC POWER SUPPLY

The outputs are powered by an internal, transformer isolated, purely AC dynamic power supply that efficiently transfers the AC reference input power to the outputs, in a natural AC flowing format yielding very low loss.

The power supply produces unfiltered, full-wave rectified positive and negative voltages. These voltages are always in phase with the amplifier output voltages since the power is derived from the reference input.

Optimum efficiency is achieved by essentially using as much AC direct power transfer as possible to drive the AC outputs because there is no DC conversion in the power transfer and the amplitude of the internal AC power rails need only be a few volts greater than the voltages driven on the outputs.

Because the outputs are allowed to follow the reference input (synchro's and converters use ratio accuracy), these supplies only need to be a small percentage higher in voltage than the amplifiers maximum output voltage to accommodate the headroom required of the circuit.

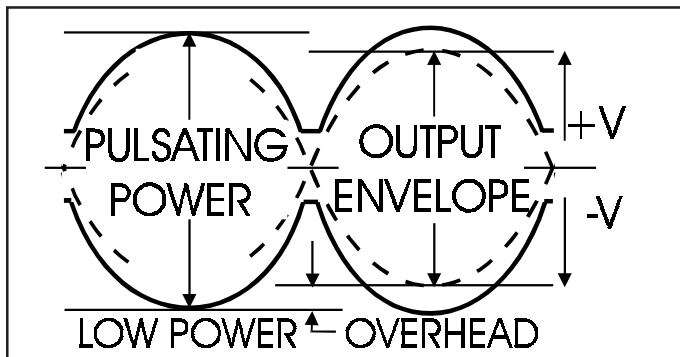
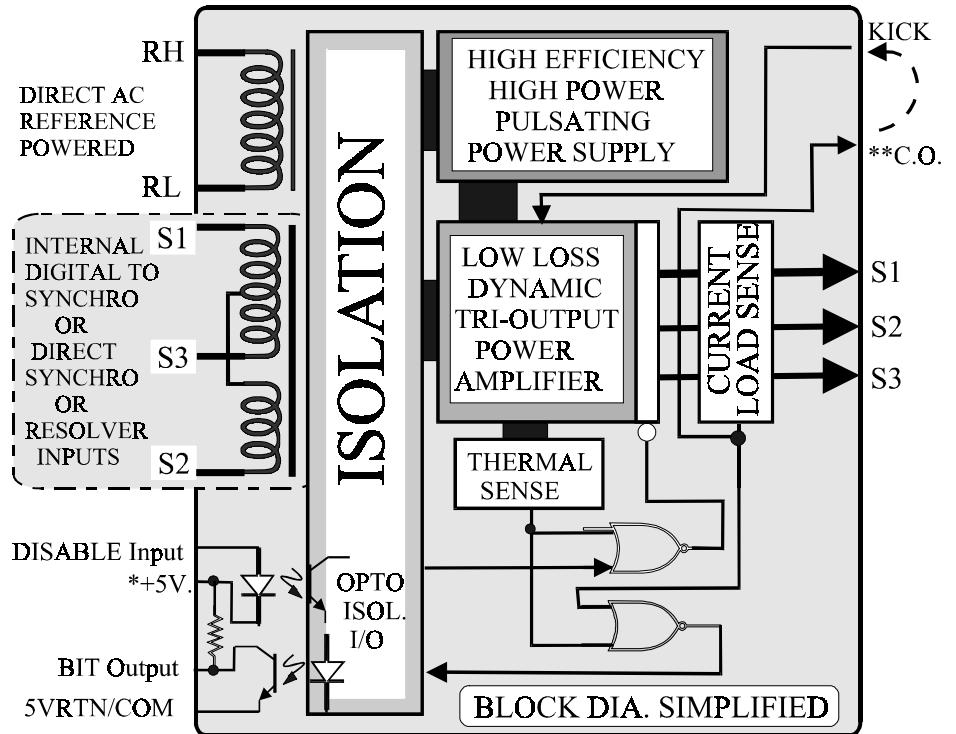

Fig. PPS, AC Pulsating Power Transfer

The lower the voltage differential required input to output (considering the internal transformers), to drive the load; the minimum the power loss (in the form of heat), and the greater the efficiency of the amp.

Using this AC pulsating power technique, the output signals are tightly coupled to the reference input and the only power dissipated is the current times the small voltage difference between the pulsating power stage and the synchro signal outputs.

Because both the power stage and the signal outputs are



*-P option includes internal isolated +5VDC supply. **For Driving TR's (Already Included on all units with internal D-S.) Jump on connector

sinusoidal, and the power stages headroom is very small, the power required to drive the load is minimal. Thus the Reference Powered Synchro Amplifiers provide the highest efficiency attainable, low loss, and minimum heat dissipation.

Because there is no internal high frequency PWM or charge-pump switching, there is no RF switching noise emitted from the unit or discontinuity in the outputs to compromise other user circuits, and the outputs are inherently compatible with all and any existing synchro converters.

Using this type of "dynamic power transfer technique", the efficiency is nominally better than 80% and loss (power dissipation & heat generation) for reactive loads is less than half that of conventional DC powered amplifiers.

Care should be taken to minimize the phase shift between the reference and signal inputs. Since the power supplies

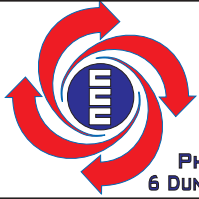

COMPUTER CONVERSIONS CORPORATION

WWW.COMPUTERCONVERSIONS.COM
PHONE: (631)261-3300 FAX: 261-3308
6 DUNTON CT., E. NORTHPORT, NEW YORK, USA 11731

SPA & DSPH SERIES REFERENCE POWERED, HIGH VA. SYNCHRO AMPLIFIERS or D-S pg.3

are only a few volts greater than the signal, the output could be affected by phase shift. Phase shift effect, compensation, and management techniques are detailed in CCC app. note Synapp.pdf "Driving Synchro Loads".

Packaging/Conductive Cooling

These models are all self-contained in a easy to install "Bolt-On" bulkhead mount chassis. The chassis is a light weight, single piece aluminum, 1/8" min. thick solid base plate, that provides excellent thermal transfer for conductive cooling of the unit.

Mounting and Thermal Considerations:

Since the unit is primarily conduction cooled, make sure that it is tightly mounted to an appropriately large, thermally conductive (unpainted) surface. Thermal grease can also be applied to the mounting surface.

Kick Circuit

For Torque Receiver applications, a kick circuit is provided to free stalled rotors, simply wire a jumper between the "CO" (current overload) output, and the "Kick" input.

More common an occurrence with large digital or switched step inputs, or after power up; a synchro torque receiver may get hung up at a false null, and just sit there and vibrate while draining large circulating currents. The amplifier will sense the overload that occurs if the rotor is persistently drawing too much current trying (unsuccessfully) to move the shaft load, and (with the kick/CO jumper installed) the amp. will automatically shift the output by 120 degrees for a nominal 1/2 second duration to free the rotor from the false null.

Once the rotor is put in motion it has greater control of its output. Use this feature only if at least one Torque Receiver is being driven from the outputs.

Disable Input

The disable input is a TTL compatible Opto-Isolated input used to provide a circuit-safe means of disabling (turning off & on) the amplifier outputs for various applications. When disabled, the outputs appear as an open circuit to the load.

The disable can be used to sequentially power up the synchro amps. if several are used in a power sensitive application, or when used where the the synchro signal outputs are going through switching relays for auxiliary, back-up, or test systems.

By disabling the outputs prior to switching either the reference/power inputs or the stator outputs, or both, and then driving the synchro-amp. inputs to match the angle dictated on the destination source prior enabling the outputs; the relays can very safely switch these points without any appreciable power demand during the actual switching. This will provide a very smooth transition that will reduce surges, and inductive con-

tent, allowing the user to minimize the required size of the relays, and dramatically increase the life of any relays used for switching these (high power) terminations.

A logic 1 is used to disable the power outputs, a logic 0 will enable the outputs providing the unit is powered and is not in a thermal overload sensed condition.

BIT Output

The Built-in-test output is a TTL compatible Opto-Isolated output that uses a logic level 1 to indicate that the amplifier has sensed either a thermal overload condition forcing it to shut down its outputs until the internal temperature cools down, or a current overload that is straining and thereby distorting the outputs, until the load is recovered (or kicked to free a stalled rotor), or if in thermal overload (when the internal temperature sense shuts down the outputs).

Current-Load Sense

The output current on 25VA units is limited to 1.0 amp peak, and approximately 1 amp/25VA on larger units, after a 4 second nominal delay; an overcurrent indication is sensed, setting the BIT output to a logic 1 (See Built-in-test, above).

When Driving Torque Receivers, the current limiting is typically experienced whenever the rotor is off null (any significant difference in angle, from where it is being commanded to go), typically activating the kick circuit to rapidly set the driven synchro in motion (to free the rotor from hang-up), allowing the rotor to move towards its commanded angle (= null).

Thermal Sense

These synchro amplifiers are thermally protected, the amplifier outputs will shut down when the internal temperature reaches 125°C, also setting the BIT output to a logic 1. Thermal overload recovers when the internal temperature recovers.

~~~~~SPECIFICATIONS~~~~~

### Digital Inputs/Outputs: (All Units)

\***Disable...Input (DIS):** Logic "0" = L= OVDC Enables Power Amplifier Output, TTL Compatible, requires 2.5ma. at logic 0

\*\* Isolation: OptoIsolated - 1000V Peak min. Break-down voltage to Ground.

**Built-in-Test..Output, Overload Indicator (BIT):** logic level 1= H, drives 2 TTL loads, indicates amplifier sensed over load condition forcing it to shut down its outputs until conditions are satisfied (see txt).

\*\* Isolation: OptoIsolated - 1000V Peak min. to Gnd..

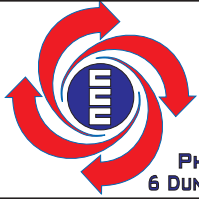

# COMPUTER CONVERSIONS CORPORATION

WWW.COMPUTERCONVERSIONS.COM  
PHONE: (631)261-3300 FAX. 261-3308  
6 DUNTON CT., E. NORTHPORT, NEW YORK, USA 11731

## SPA & DSPH SERIES REFERENCE POWERED, HIGH VA. SYNCHRO AMPLIFIERS or D-S pg.4

### SPECIFICATIONS

### SYNCHRO OUTPUTS:

**Kick Circuit: Kick & CO** (kick input & current over load) are normally connected for Torque Receiver Loads (not for Passive CT or CDX loads); If Output is hung-up due to excessive current output; Shifts output 120° for .5 sec. to unjam rotor hang-up.(see txt.)

### Synchro Output: 90V. Output Models: 90V L-L +1%:

25VA Models: Drives Zso = 243 Ohms  
(Passive CT & CDX type loads)  
Drives Zss = 6 Ohms (Active Torque Receiver loads)  
30VA Models: Drive Zso = 202 Ohms, Zss = 6 Ohms.  
50VA Models: Drives: Zso = 122 , Zss = 3 Ohms  
100VA Models: Drives: Zso = 61, Zss = 1.5 Ohms

- Notes:** \*1)Providing unit is not in thermal overload; internal Temperature is less then 125°C.  
\*2) Synchro Outputs when disabled are as open circuit, high impedance state.  
\*\*\*3) On D-S units (having internal Digital to Synchro Converter); no external +5VDC is required, uses internal isolated +5VDC supply, the +5VRTN (see block dia.) is same as the digital data common only.

### Synchro Output: Models: 11.8V L-L +1%, :

15VA Models: Drives: Zso = 6.9 Ohms  
25VA Models: Drives Zso = 4.2 Ohms

### **© Computer Conversions Corp. 1997 - 2012**

### SIGNAL INPUTS:

#### P/N

#### **Code \*Type Inputs**

- (A) Synchro: 90V L-L 400Hz ±10% (400 Hz)  
Impedence = 400K Ohms min. balanced  
(A) Synchro: 90V L-L 60Hz ±5% (60 & 60/400 Hz.)  
Impedence = 100K Ohms min. balanced  
(B) \*\*Resolver: 6.81V L-L @ 400Hz. or 60 Hz. ±10%  
Impedence = 4K Ohms min. balanced  
(C) \*\*\*Resolver: 6.0V L-L @ 400Hz. or 60 Hz. ±10%  
Impedence = 4K Ohms min. balanced  
(D) Synchro: 11.8V.L-L @ 400Hz.±10%  
Impedence = 26K Ohms min. balanced

#### Notes:

- \*1) P/N Codes See Model Selection Guide  
\*\*2) Typical Resolver Input format for synchro outputs: when driven by a D-R converter operating on ±15 VDC supplies.  
\*\*\*3) When driven by a D-R converter operating on ±12 VDC supplies.

**SIGNAL INPUT ISOLATION:** Internally Transformer Isolated; 500VDC min. Breakdown Voltage to Gnd.

#### **DC Power Input for BIT/EN Opto-Isolators:**

+5V D.C. ±10% @ 10ma MAX.

(Not Required on -P units, add a P to end of P/N)

### **\*ACCURACY:**

±3 arc. minutes for passive CT & CDX loads  
±6 arc minutes typical, +/- 10 arc. minutes worse case for active Torque Receiver (TR) type loads.

\* Shown for Synchro Amplifier Types,  
for internal 14 bit D-S add 4, 16 bit add 2, arc minutes .

### **\*REFERENCE POWER INPUT: (Amplifiers)**

#### **\*\* 90V.Signals, 25VA Models:**

(400 Hz.) 115V. RMS ±10%, 360-440 Hz. @ 60 ma.\*\*  
(60 Hz.) 115V. RMS ±10%, 57-63 Hz.. @ 100 ma.\*\*  
(60 & 400) 115V. RMS ±10%, 57-440 Hz. @ 100 ma.\*\*

#### **90V. Signals, 60 Hz. 100VA Model: (Typical/Measured)**

725 ma. no load, + 1.122ma. of input / ma. of output.

#### **\*\* 11.8V.Signals, 25VA Models:**

(400Hz) 26V. RMS ±10%, 360-440 Hz. @ n1 ma.  
(No load) plus n2 ma. per ma. of output load.

### **TEMPERATURE: (BEST IN CLASS !)**

**Operating Temperature Range:** -40°C to +85°C

**Storage Temperature Range:** -55°C to +125°C

**Heat Dissipation:** 1.5 watts / VA to load. (25 & 30VA.)

#### Notes:

- \*1)Reference input must be in phase with signal inputs and signal outputs  
\*\*2) (No load) plus 1 ma. per ma. of output load.  
3) 25VA units; 1 A. typ. draw w/ output short circuit.

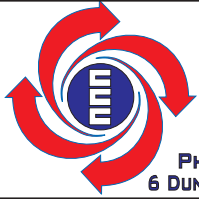

**COMPUTER  
CONVERSIONS  
CORPORATION**  
WWW.COMPUTERCONVERSIONS.COM  
PHONE: (631)261-3300 FAX: 261-3308  
6 DUNTON CT., E. NORTHPORT, NEW YORK, USA 11731

## SPA & DSPH SERIES MODEL SELECTION GUIDE WITH WEIGHTS AND SIZES

MODEL SELECTION GUIDE FOR SYNCHRO POWER BOOSTERS (AMPLIFIERS)

| MODEL        | Option Internal +5VDC used for EN/BIT | Output POWER VA | Frequency               | INPUTS -POWER & SIGNALS  |                              |                               | OUTPUTS                          | WEIGHT    | SIZE                                          |
|--------------|---------------------------------------|-----------------|-------------------------|--------------------------|------------------------------|-------------------------------|----------------------------------|-----------|-----------------------------------------------|
|              |                                       |                 |                         | Reference & POWER INPUTS | SIGNAL INPUTS V.L-L Balanced | SIGNAL INPUT FORMAT SYN./RES. | Synchro Format in V.L-L Balanced | WEIGHT    | Package Drawing Code                          |
| SPA2560-A    | -P                                    | 25VA            | 60Hz.                   | 115VAC                   | 90V.L-L                      | Synchro                       | 90V.L-L                          | 4.75 lbs. | B<br>7.4"L x 2.6"H                            |
| SPA2560-B    | -P                                    |                 |                         |                          | 6.81V.L-L                    | Resolver Sin/Cos              |                                  |           |                                               |
| SPA2560-C    | -P                                    |                 |                         |                          | 6.0V.L-L                     |                               |                                  |           |                                               |
| SPA2540-D-P  | included                              | 25VA            | 400Hz.                  | 26/115VAC                | 11.8                         | Synchro                       | 11.8V.L-L                        | 3.25 lbs  | A<br>5.09"W x<br>7.4"L x<br>1.84"H            |
| SPA2540-A    | -P                                    |                 |                         | 115VAC                   | 90                           | Synchro                       | 90V.L-L                          | 3.25 lbs  |                                               |
| SPA2540-B    | -P                                    |                 |                         |                          | 6.81V.L-L                    | Resolver Sin/Cos              |                                  |           |                                               |
| SPA2540-C    | -P                                    |                 |                         |                          | 6.0V.L-L                     |                               |                                  |           |                                               |
| SPA25B-A     | -P                                    | 25VA            | BOTH<br>60 or<br>400Hz. | 115VAC                   | 90                           | Synchro                       | 90V.L-L                          | 4.75 lbs. | B<br>7.4"L x 2.6"H                            |
| SPA25B-B     | -P                                    |                 |                         |                          | 6.81V.L-L                    | Resolver Sin/Cos              |                                  |           |                                               |
| SPA25B-C     | -P                                    |                 |                         |                          | 6.0V.L-L                     |                               |                                  |           |                                               |
| SPA3060-A    | -P                                    | 30VA            | 60Hz.                   | 115VAC                   | 90                           | Synchro                       | 90V.L-L                          | 4.75 lbs. | B<br>7.4"L x 2.6"H                            |
| SPA3060-B    | -P                                    |                 |                         |                          | 6.81V.L-L                    | Resolver Sin/Cos              |                                  |           |                                               |
| SPA3060-C    | -P                                    |                 |                         |                          | 6.0V.L-L                     |                               |                                  |           |                                               |
| SPA3040-A    | -P                                    | 30VA            | 400Hz.                  | 115VAC                   | 90                           | Synchro                       | 90V.L-L                          | 4.75 lbs. | A<br>7.4"L x<br>1.84"H                        |
| SPA3040-B    | -P                                    |                 |                         |                          | 6.81V.L-L                    | Resolver Sin/Cos              |                                  |           |                                               |
| SPA3040-C    | -P                                    |                 |                         |                          | 6.0V.L-L                     |                               |                                  |           |                                               |
| SPA5060-A    | -P                                    | 50VA            | 60Hz.                   | 115VAC                   | 90                           | Synchro                       | 90V.L-L                          | 7.0 lbs.  | C<br>5.1"W x<br>9.31"L x<br>2.75"H            |
| SPA5060-B    | -P                                    |                 |                         |                          | 6.81V.L-L                    | Resolver Sin/Cos              |                                  |           |                                               |
| SPA5060-C    | -P                                    |                 |                         |                          | 6.0V.L-L                     |                               |                                  |           |                                               |
| SPA1040-A    | -P                                    | 100VA           | 400Hz.                  | 115VAC                   | 90                           | Synchro                       | 90V.L-L                          | 5.75 lbs  | C<br>5.1"W x<br>5.1"w x<br>9.31"L x<br>2.75"H |
| SPA1040-B    | -P                                    |                 |                         |                          | 6.81V.L-L                    | Resolver Sin/Cos              |                                  |           |                                               |
| SPA1040-C    | -P                                    |                 |                         |                          | 6.0V.L-L                     |                               |                                  |           |                                               |
| SPA1060-A    | -P                                    | 100VA           | 60Hz.                   | 115VAC                   | 90                           | Synchro                       | 90V.L-L                          | 8.0 lbs.  | D<br>5.1"W x<br>5.1"w x<br>9.31"L x<br>3.31"H |
| SPA1060-B    | -P                                    |                 |                         |                          | 6.81V.L-L                    | Resolver Sin/Cos              |                                  |           |                                               |
| SPA1060-C    | -P                                    |                 |                         |                          | 6.0V.L-L                     |                               |                                  |           |                                               |
| SPA10B-A     | -P                                    | 100VA           | BOTH<br>60 or<br>400Hz. | 115VAC                   | 90                           | Synchro                       | 90V.L-L                          | 8.0 lbs.  | D<br>5.1"w x<br>9.31"L x<br>3.31"H            |
| SPA10B-B     | -P                                    |                 |                         |                          | 6.81V.L-L                    | Resolver Sin/Cos              |                                  |           |                                               |
| SPA10B-C     | -P                                    |                 |                         |                          | 6.0V.L-L                     |                               |                                  |           |                                               |
| SPA20040-A   | -P                                    | 200VA           | 400Hz                   | 115VAC                   | 90V.L-L                      | Synchro                       | 90V.L-L                          | 24.0 lbs. | C7972<br>8.8"w x                              |
| SPB2054-52-B | -P                                    | 200VA           | 50,60 or<br>400Hz.      | 110VAC                   | 6.81V.L-L                    | Resolver Sin/Cos              | 52V.L-L                          | 24.0 lbs. | 15.0"L x<br>3.7"H                             |

NOTES: 1) Add -P to end of Model for units with internal +5VDC Power Supply. (No External Supplies Required)  
 2) Use 6.81V. Signal inputs when driven by Bus Cards PCI, VME, D-S cards using +/-15VDC .  
 3) Use 6.0V. Signal inputs when driven with Bus Cards PCI, VME, D-S cards using +/-12VDC Supplies  
 4) Use E in part number in lieu of -A, -B, -C, when driven by our cPCI Cards.

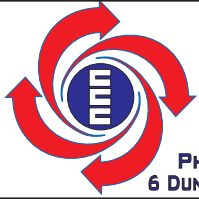

# COMPUTER CONVERSIONS CORPORATION

WWW.COMPUTERCONVERSIONS.COM  
 PHONE: (631)261-3300 FAX: 261-3308  
 6 DUNTON CT., E. NORTHPORT, NEW YORK, USA 11731

## SPA SERIES Outline Dimensions and Pinouts & Installation Notes

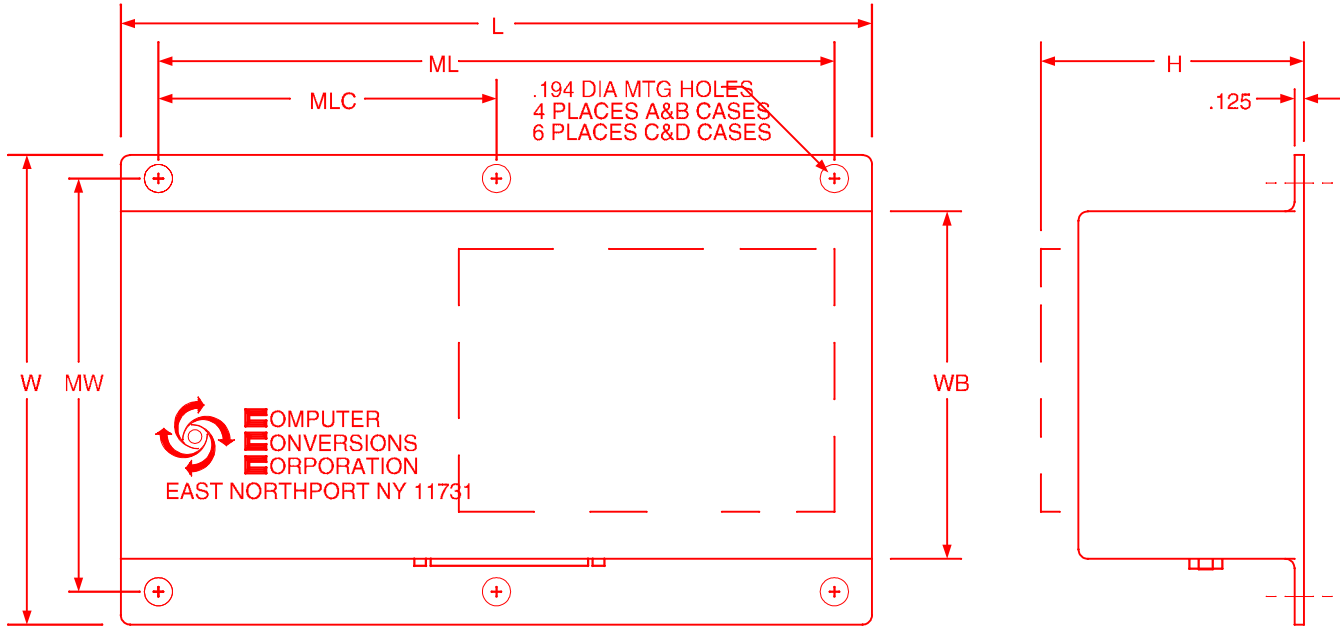

© Computer Conversions Corp. 1997, 2001, 2011

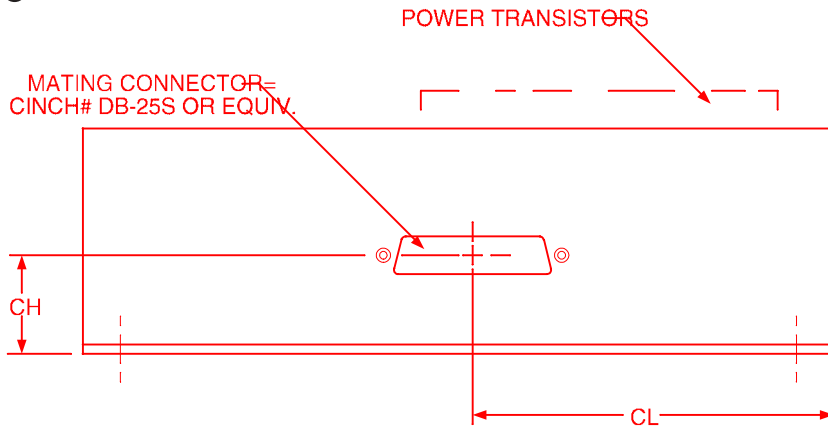

| SIZE | L    | W    | H    | WB    | ML    | MLC   | MW   | CL    | CH    |
|------|------|------|------|-------|-------|-------|------|-------|-------|
| A    | 7.40 | 5.09 | 1.84 | 4.25  | 6.75  | -     | 4.70 | 3.625 | .836  |
| B    | 7.40 | 5.09 | 2.60 | 4.25  | 6.75  | -     | 4.70 | 3.625 | 1.616 |
| C    | 9.31 | 5.10 | 2.75 | 4.125 | 8.687 | 4.343 | 4.70 | 3.26  | .91   |
| D    | 9.31 | 5.10 | 3.31 | 4.125 | 8.687 | 4.343 | 4.70 | 3.26  | 1.21  |

| CONNECTOR I/O  |             |                |             |
|----------------|-------------|----------------|-------------|
| SIZE "A" & "B" |             | SIZE "C" & "D" |             |
| PIN            | FUNCTION    | PIN            | FUNCTION    |
| 23             | RH 115VAC   | 20             | } RH        |
| 24             | RL          | 21             |             |
| 9              | S1 IN(COM)  | 22             | } RL        |
| 10             | S3 IN (SIN) | 23             |             |
| 12             | S2 IN(COS)  | 24             |             |
| 11             | S4 IN(COM)  | 25             |             |
| 4              | S1 OUT      | 7              | S1 IN(COM)  |
| 21             | S2 OUT      | 9              | S3 IN (SIN) |
| 17             | S3 OUT      | 8              | S2 IN(COS)  |
| 14             | ENABLE      | 10             | S4 IN(COM)  |
| 6              | K           | 11             | } S1 OUT    |
| 18             | CO          | 12             |             |
| 2              | BITE OUT    | 13             | } S2 OUT    |
| 1              | +5V         | 14             |             |
| 16             | GND         | 15             | } S3 OUT    |
| 7              | TP          | 16             |             |
| 3              | -           | 1              | } S3 OUT    |
| 5              | -           | 2              |             |
| 8              | -           | 3              |             |
| 13             | -           | 19             | ENABLE      |
| 15             | -           | 6              | K           |
| 19             | -           | 18             | CO          |
| 20             | -           | 17             | BITE OUT    |
| 22             | -           | 4              | +5V         |
| 25             | RH 26VAC    | 5              | GND         |

Mating connectors are supplied.

**Notes:**

- 1) Drawing is Not to Scale, see table.
- 2) These are Conduction Cooled Units, designed to be bolted to a Bulk-Head . Mount to a thermally conductive surface of sufficient mass, having good thermal conductivity, using thermal grease on the 2 mounting tabs bottom surfaces. If desired Fans and heat sinks with fins could be added to improve cooling.
- 3) Heat to be Dissipated is 1.5 Watt maximum per VA of output being delivered.
- 4) Dotted Lines show area of power drivers having non-conductive surfaces.
- 5) S4 is not used on Synchro input units, = no connect.,
- 6) TP are internal factory test points = no connect, - represents no connect.
- 7) Models > 30VA; sizes C and D, outputs are doubled up to facilitate higher power., Connectors facilitate 16 awg. wire max.